

50x50x15 mm

- * Frame: Plastic (Black) 94V-0
- * Impeller: Plastic (Black) 94V-0
- * Lead Wires: UL type or Equivalent, AWG#28, Red +, Black -
- * Operating Temperature: -25°C~+70°C, 5%~90%RH
- * Storage Temperature: -40°C~+80°C, 5%~90%RH
- * Weight: 28.0g

■ Dimensions(Unit:mm)

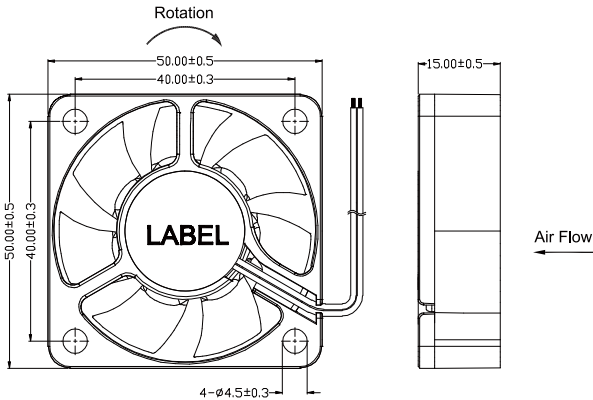

■ Mounting panel cutout(Unit:mm)

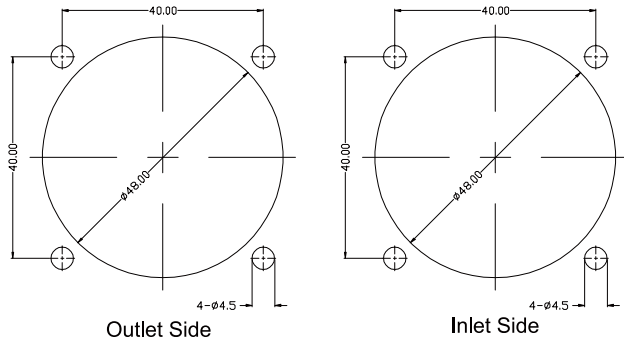

■ Specifications

Model No.	Rated Voltage	Operating Voltage	Rated Current	Speed	Max. Air Flow		Max. Static Pressure		Noise
	VDC	VDC	A	RPM	m ³ /min	CFM	mmH ₂ O	inH ₂ O	dB
HD5015L05	5	4.0~5.75	0.20	3500	0.20	7.10	2.70	0.11	23.3
HD5015M05	5	4.0~5.75	0.30	4500	0.24	8.50	3.40	0.13	30.5
HD5015H05	5	4.0~5.75	0.40	5500	0.29	10.10	4.30	0.17	36.3
HD5015L12	12	7.0~13.8	0.09	3500	0.20	7.10	2.70	0.11	23.3
HD5015M12	12	7.0~13.8	0.13	4500	0.24	8.50	3.40	0.13	30.5
HD5015H12	12	7.0~13.8	0.18	5500	0.29	10.10	4.30	0.17	36.3
HD5015L24	24	14.0~27.6	0.06	3500	0.20	7.10	2.70	0.11	23.3
HD5015M24	24	14.0~27.6	0.09	4500	0.24	8.50	3.40	0.13	30.5
HD5015H24	24	14.0~27.6	0.13	5500	0.29	10.10	4.30	0.17	36.3

Note:

Bearing Type: Ball Bearing-----B, Sleeve Bearing-----S, Hydraulic Bearing-----R

Function description:

A:3rd Pulse Wire F:Techometer / Speed Sensor R:Alarm/high
 Q:Alarm/low S:Alarm/high-low W:PWM Control input



■ P&Q Curve

