

HD2510 SERIES

25x25x10 mm

- * Frame: Plastic (Black) 94V-0
- * Impeller: Plastic (Black) 94V-0
- * Lead Wires: UL type or Equivalent, AWG#28, Red +, Black -
- * Operating Temperature: -25°C~+70°C, 5%~90%RH
- * Storage Temperature: -40°C~+80°C, 5%~90%RH
- * Weight: 7.0g



■ Dimensions(Unit:mm)

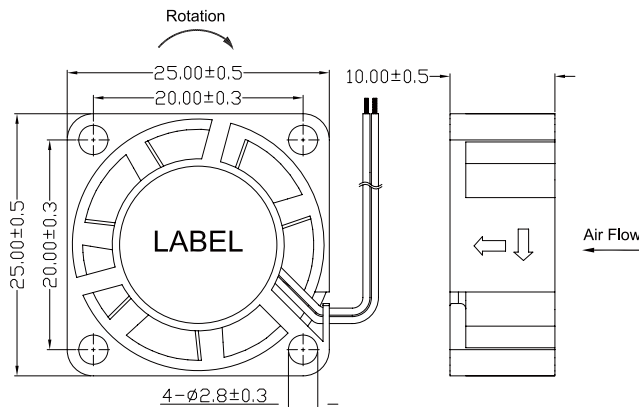

■ Mounting panel cutout(Unit:mm)

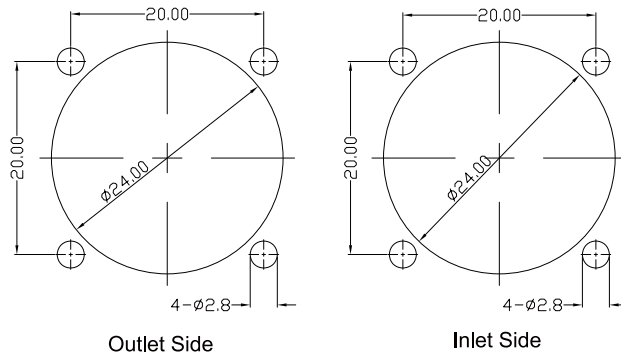

■ P&Q Curve

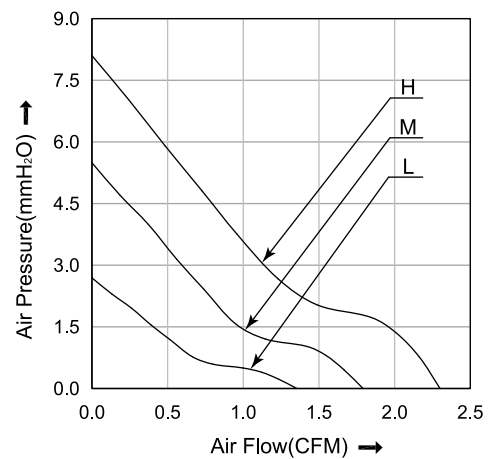

■ Specifications

Model No.	Rated Voltage	Operating Voltage	Rated Current	Speed	Max. Air Flow		Max. Static Pressure		Noise
	VDC	VDC	A	RPM	m ³ /min	CFM	mmH ₂ O	inH ₂ O	dB
HD2510L05	5	4.0~5.75	0.13	7000	0.04	1.30	3.10	0.12	20.0
HD2510M05	5	4.0~5.75	0.21	10000	0.05	1.80	5.50	0.22	26.0
HD2510H05	5	4.0~5.75	0.30	13000	0.07	2.30	8.10	0.32	33.0
HD2510L12	12	7.0~13.8	0.06	7000	0.04	1.30	3.10	0.12	20.0
HD2510M12	12	7.0~13.8	0.09	10000	0.05	1.80	5.50	0.22	26.0
HD2510H12	12	7.0~13.8	0.13	13000	0.07	2.30	8.10	0.32	33.0

Note:

Bearing Type: Ball Bearing-----B, Sleeve Bearing-----S, Hydraulic Bearing-----R

Function description:

A:3rd Pulse Wire F:Tachometer / Speed Sensor R:Alarm/high

Q:Alarm/low S:Alarm/high-low W:PWM Control input