

HD1751 SERIES

172x150x51 mm

- * Frame: Plastic (Black) 94V-0
- * Impeller: Plastic (Black) 94V-0
- * Lead Wires: UL type or Equivalent, AWG#28, Red +, Black -
- * Operating Temperature: -25°C~+70°C, 5%~90%RH
- * Storage Temperature: -40°C~+80°C, 5%~90%RH
- * Weight: 665.0g

■ Dimensions(Unit:mm)

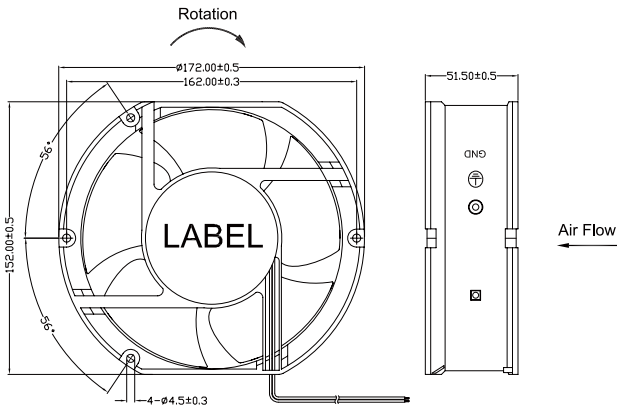

■ Mounting panel cutout(Unit:mm)

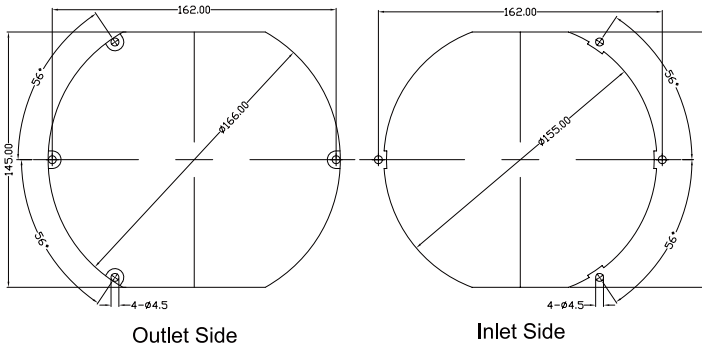

■ P&Q Curve

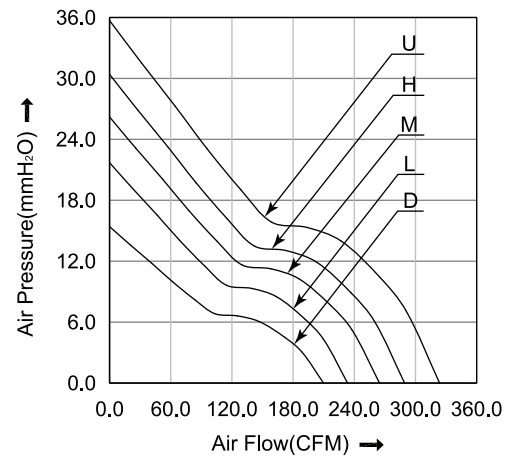

■ Specifications

Model No.	Rated Voltage	Operating Voltage	Rated Current	Speed	Max. Air Flow		Max. Static Pressure		Noise
	VDC	VDC	A	RPM	m ³ /min	CFM	mmH ₂ O	inH ₂ O	dB
HD1751L12	12	7.0~13.8	1.50	3100	5.95	210.10	15.40	0.61	54.5
HD1751M12	12	7.0~13.8	2.00	3500	6.78	239.60	22.10	0.87	58.0
HD1751H12	12	7.0~13.8	3.00	4000	7.87	278.10	27.90	1.10	62.7
HD1751D24	24	14.0~27.6	0.70	3100	5.95	210.10	15.40	0.61	54.5
HD1751L24	24	14.0~27.6	1.00	3500	6.61	233.40	21.70	0.85	57.5
HD1751M24	24	14.0~27.6	1.30	3800	7.49	264.70	26.10	1.03	61.5
HD1751H24	24	14.0~27.6	1.50	4100	8.19	289.30	30.40	1.20	63.6
HD1751U24	24	14.0~27.6	2.00	4500	9.16	323.60	35.70	1.41	65.1
HD1751D48	48	28.0~56.0	0.40	3100	5.95	210.10	15.40	0.61	54.5
HD1751L48	48	28.0~56.0	0.50	3500	6.61	233.40	21.70	0.85	57.5
HD1751M48	48	28.0~56.0	0.60	3800	7.49	264.70	26.10	1.03	61.5
HD1751H48	48	28.0~56.0	0.70	4100	8.19	289.30	30.40	1.20	63.6
HD1751U48	48	28.0~56.0	1.00	4500	9.16	323.60	35.70	1.41	65.1

Note:

Bearing Type: Ball Bearing-----B, Sleeve Bearing-----S, Hydraulic Bearing-----R

Function description:

A:3rd Pulse Wire

F:Techometer / Speed Sensor

R:Alarm/high

Q:Alarm/low S:Alarm/high-low

W:PWM Control input