

HB4010 SERIES

40x40x10 mm

- * Frame: Plastic (Black) 94V-0
- * Impeller: Plastic (Black) 94V-0
- * Lead Wires: UL type or Equivalent, AWG#28, Red +, Black -
- * Operating Temperature: -25°C~+70°C, 5%~90%RH
- * Storage Temperature: -40°C~+80°C, 5%~90%RH
- * Weight: 12.0g



■ P&Q Curve

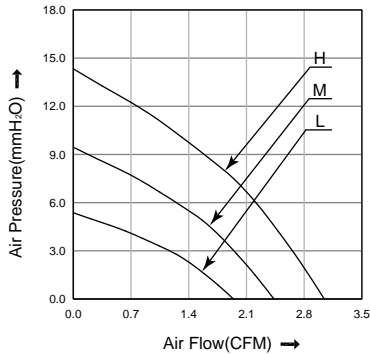

■ Dimensions (Unit:mm)

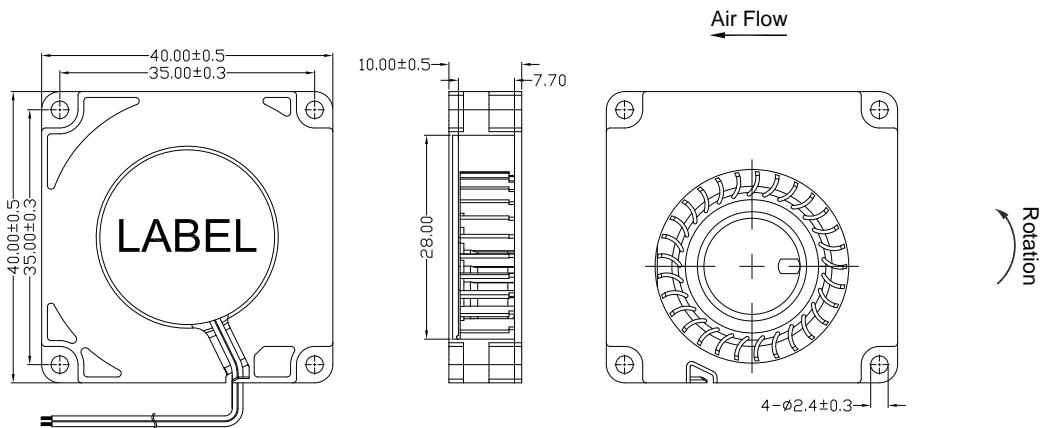

■ Specifications

| Model No. | Rated Voltage | Operating Voltage | Rated Current | Speed | Max. Air Flow | | Max. Static Pressure | | Noise |
|-----------|---------------|-------------------|---------------|-------|---------------------|------|----------------------|--------------------|-------|
| | VDC | VDC | A | RPM | m ³ /min | CFM | mmH ₂ O | inH ₂ O | |
| HB4010L05 | 5 | 4.0~5.75 | 0.09 | 5500 | 0.05 | 1.94 | 5.37 | 0.21 | 28.0 |
| HB4010M05 | 5 | 4.0~5.75 | 0.13 | 7000 | 0.07 | 2.43 | 9.45 | 0.37 | 31.0 |
| HB4010H05 | 5 | 4.0~5.75 | 0.18 | 8500 | 0.08 | 3.00 | 14.33 | 0.56 | 34.5 |
| HB4010L12 | 12 | 7.0~13.8 | 0.06 | 5500 | 0.05 | 1.94 | 5.37 | 0.21 | 28.0 |
| HB4010M12 | 12 | 7.0~13.8 | 0.09 | 7000 | 0.07 | 2.43 | 9.45 | 0.37 | 31.0 |
| HB4010H12 | 12 | 7.0~13.8 | 0.13 | 8500 | 0.08 | 3.00 | 14.33 | 0.56 | 34.5 |

Note:

Bearing Type: Ball Bearing-----B, Sleeve Bearing-----S, Hydraulic Bearing-----R

Function description:

A:3rd Pulse Wire F:Techometer / Speed Sensor R:Alarm/high
 Q:Alarm/low S:Alarm/high-low W:PWM Control input